

Bočni pomak hidraulične ruke u levo / u desno



Karakteristike bagera	WE20E
Opetarivna težina	2000kg
Kapacitet kašike	0.05 m ³ / 500kg
Širina kope za kopanje	420 mm / 200 mm
Motor 	Yanmar (3TNV70-S) JAPAN
Snaga motora	10kw/2200r/min
Zapremina motora	0.854L
Tip	3 cilindra, vodeno hlađenje
Pumpa	JAPAN NAICH
Protok pumpe	23.3 L/Min
Kapacitet rezervoara za hidrauliku	15.3L
Kapacitet rezervoara za motorno ulje	2.8 (1.3) L
Kapacitet dizel rezervoara	19 L
Ventili	JAPAN KYB
Motor za okretanje platforme bagera	EATON - USA
Motor za kretanje	EATON - USA
Sila kopanja kašike	13.5 Kn
Sila kopanja ruke	10.1 Kn
Maksimalna vuča	17.5 Kn
Specifični pritisak na tlo	32.8 KPA

Dimenzije

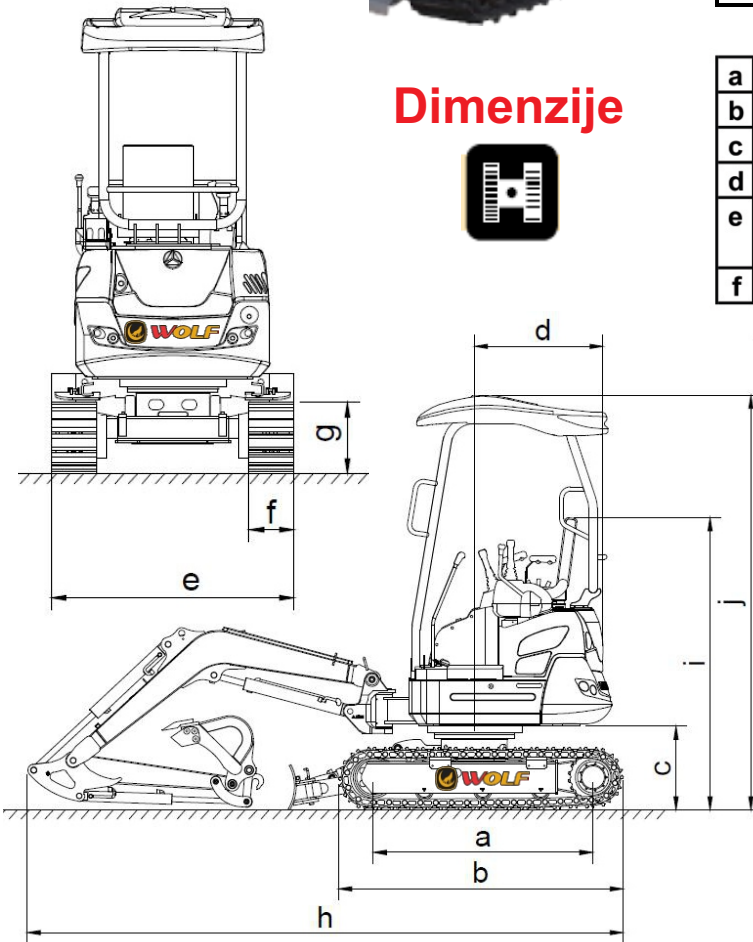

a	1230 mm	g	360 mm
b	1590 mm	h	3400 mm
c	473 mm	i	1660 mm
d	740 mm	j	2380 mm
e	990 mm	k	390 mm
	(1240) mm	l	510 mm
f	230 mm		

A	3610 mm	G	1580 mm
B	3700 mm	H	275 mm
C	2150 mm	I	180 mm
D	3275 mm		
E	2310 mm		
F	1740 mm		

Bočni pomak hidraulične ruke u levo / u desno
