

FORESTRY TILLERS

SSM - SSM/HP

Fixed tooth tiller for medium/high power tractors.

The SSM has been designed and built to be used with medium to high-power tractors (150 to 300 hp). It clears land perfectly, shredding logs up to 50 cm in diameter at a max. depth of 40 cm. SSM also comes in an HP model for tractors up to 300 hp. Both models can be equipped with Standard or Heavy Duty teeth

to work in different soils and ensure the superb performance required to meet different needs. Available options include forestry counter blades for wood clearing, a rear roller, and an automatic universal joint alignment system.



150-300 hp

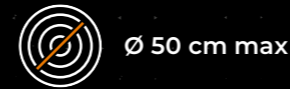

Ø 50 cm max



Depth 40 cm

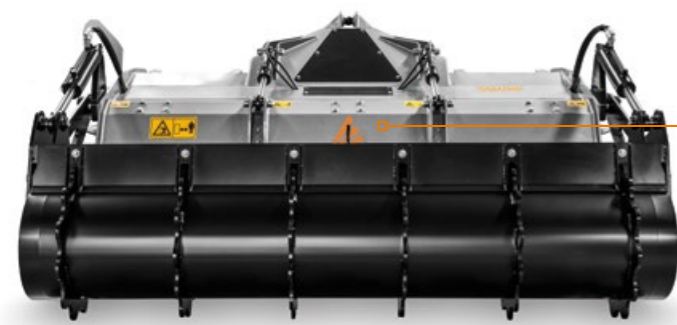

Adjustable Hardox® counter-blade

Z style self-ranging system for the PTO drive shaft/gearbox
helps keep the correct operating angle between the PTO shaft and the power take-off

Stronger transmission for tractors up to 300 hp power
(SSM/HP 200, 225 and 250)

Protection chains

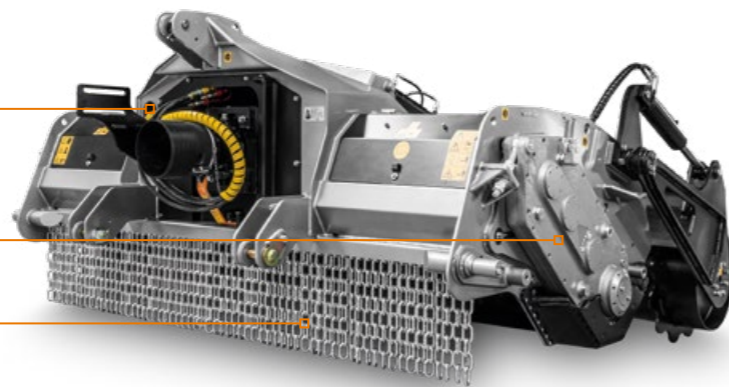

MAIN OPTIONS



W style self-aligning device between PTO drive shaft/gearbox
allows the mulcher to work in several angles without damaging the PTO



Adjustable counter-blade (forest)
for additional processing of wood material



Hydraulic controlled roller
helps with compaction and working uneven terrain

STANDARD EQUIPMENT

Hydraulic rear hood	PTO shaft with cam clutch
Enclosed machine body	Bolted-on rotor shafts (in forged steel)
Inside lateral protection	Hydraulic top link
Protection chains	Z style self ranging system of the PTO drive shaft/gearbox
Transmission with side gearbox	Flat pressed welded steel counter-blades
Gearbox with freewheel	Adjustable Hardox® counter-blade
Friction clutches	Centralized greasing hub

OPTIONS

Bolted grid on rear hood	Adjustable skids
Multiple tooth options	Dozing blade
W style self-aligning device between PTO drive shaft/gearbox	Hydraulic support roller
Adjustable counter-blade (forest)	

MODEL	SSM 200	SSM 225	SSM 250	SSM/HP 200	SSM/HP 225	SSM/HP 250
Tractor (hp)	150-250	170-250	190-250	150-300	170-300	190-300
PTO (rpm)	1000	1000	1000	1000	1000	1000
Working width (mm)	2080	2320	2560	2080	2320	2560
Total width (mm)	2410	2650	2890	2410	2650	2890
Weight (kg)	3090	3340	3590	3140	3390	3640
Rotor diameter (mm)	670	670	670	670	670	670
Max shredding diameter (mm)	500	500	500	500	500	500
Max working depth (mm)	400	400	400	400	400	400
No. teeth type A/3+MH	76+4	88+4	102+4	76+4	88+4	102+4

Data refers to machine as standard. The technical data in this catalogue may be altered without prior notice.

ROTOR TYPE A



A/3 (standard)



A/3/HD (option)



F/3 (option)



MH (side scraper)