

## FORESTRY MULCHERS

# UMH/S - UMH/S/HP

### Forestry mulchers for PTO tractors with fixed tooth rotor.

The UMH is FAE's top of the line tractor mounted forestry mulcher. It is rated for trees up to 45 cm diameter and is designed to work with high horsepower tractors. The hydrodynamic joints and the Spike Pro counter-blades guarantee optimal performance and productivity. The ergonomics of the new, fully enclosed double layer "dustproof"

frame is designed for maximum safety of the work and the operator. Finally, the large diameter of the rotor and the new Spike Pro counter-blades provide excellent homogenous shredding results. Backed by FAE's unparalleled engineering expertise, UMH/S/HP is built to last and delivers the maximum return on your investment.



240-500 hp



Ø 45 cm max

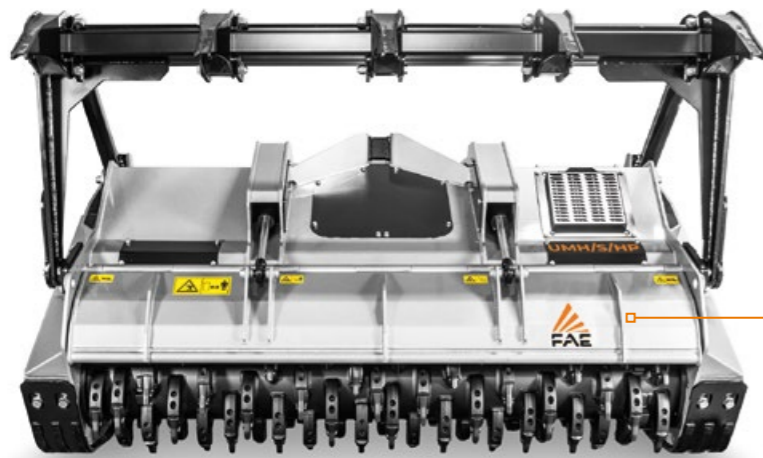

**Spike Control Pro**  
and their distribution produce  
a finer shredding result



**Centralized greasing hub**  
for easier maintenance



**Adjustable extended  
3 point hitch**  
fits perfectly with  
any kind of tractor

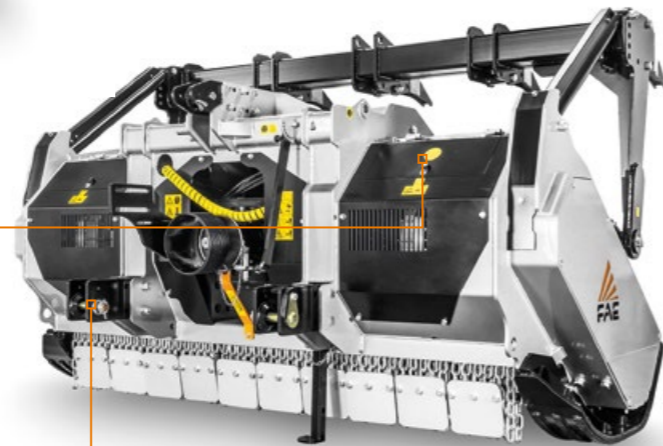

### MAIN OPTIONS



**W style self aligning device between PTO drive shaft/gearbox**  
allows the mulcher to work at several angles without damaging the PTO



**Mechanical/hydraulic push frame**  
guides and pushes material away from carrier



**Additional ripper for push frame**  
helps with the positioning of standing material while mulching



**Standard hydraulic clutch transmission**  
protects the transmission at PTO engagement for smooth starting and improves machine performance

### STANDARD EQUIPMENT

Hydraulic rear hood	Gearbox with oil cooling system (UMH/S/HP)
Inner anti wear clad plates FCP (UMH/S)	PTO shaft
Adjustable extended 3 point linkage	Cam clutch on side PTO (UMH/S)
Enclosed machine body	Bolted-on rotor shafts (in forged steel)
Centralized greasing hub	Hydraulic top link
Hydraulic hoses integrated in the frame	Z style self ranging system of the PTO drive shaft/gearbox
Cylinder protection	Gearbox with freewheel
Bolted on protection chains	Third row of interchangeable forged and hardened counter-blades (UMH/S)
Transmission with belts (UMH/S)	Interchangeable bolted on spike PRO counter-blade (UMH/S/HP)
Poly-Chain® belts transmission (UMH/S/HP)	Adjustable skids
Hydraulic clutch transmission (UMH/S/HP)	Supporting service leg

### OPTIONS

Bolt-on chain's protection plates	Special skids to go underground
Hydraulic clutch transmission (UMH/S)	Mechanical guard frame
Multiple tooth options	Hydraulic guard frame
W style self aligning device between PTO drive shaft/gearbox	Extra ripper for guard frame

MODEL	UMH/S 225	UMH/S 250	UMH/S/HP 225	UMH/S/HP 250
<b>Tractor</b> (hp)	240-400	250-400	350-500	350-500
<b>PTO</b> (rpm)	1000	1000	1000	1000
<b>Working width</b> (mm)	2320	2560	2320	2560
<b>Total width</b> (mm)	2760	3000	2760	3000
<b>Weight including rotor</b> type C/3 (kg)	4200	4440	5100	5200
type A/3 (kg)	4510	4660	5400	5500
<b>Rotor diameter</b> (mm)	680	680	680	680
<b>Max shredding diameter</b> (mm)	400	400	450	450
<b>No. teeth</b> type A/3+MH	88+2	96+2	88+2	96+2
type C/3+C/3/SS	54+2	60+2	54+2	60+2

Data refers to machine as standard. The technical data in this catalogue may be altered without prior notice.

### ROTOR TYPE A



**A/3**  
(standard)



**A/3/HD**  
(option)



**MH**  
(side scraper)

### ROTOR TYPE C



**C/3**  
(standard)



**C/3/HD**  
(option)



**K/3**  
(option)



**C/3/SS**  
(side scraper)